

Optical Specification	
Model	OPT-C10028-2M-V1.0
Resolution	5μm
Mount	C Mount
Sensor	1"
Focal Length	100
Adjustion Type	Manual
F NO.	F2.8-F16
Working Distance	2700~∞
Field Angle	1/3" (H×V×D) 2.0° × 1.5° × 2.5°
	1/2.5" (H×V×D) 2.4° × 1.8° × 3.0°
	1/1.8" (H×V×D) 3.0° × 2.3° × 3.7°
	2/3" (H×V×D) 3.7° × 2.8° × 4.6°
Distortion	< 0.05%
Weight	0.13kg
Back Focal Length	19.95
Size	Ø39.00 × 65.86
Filter	M37.5 × P0.5
Working Temperature	-20°C ~ +60°C

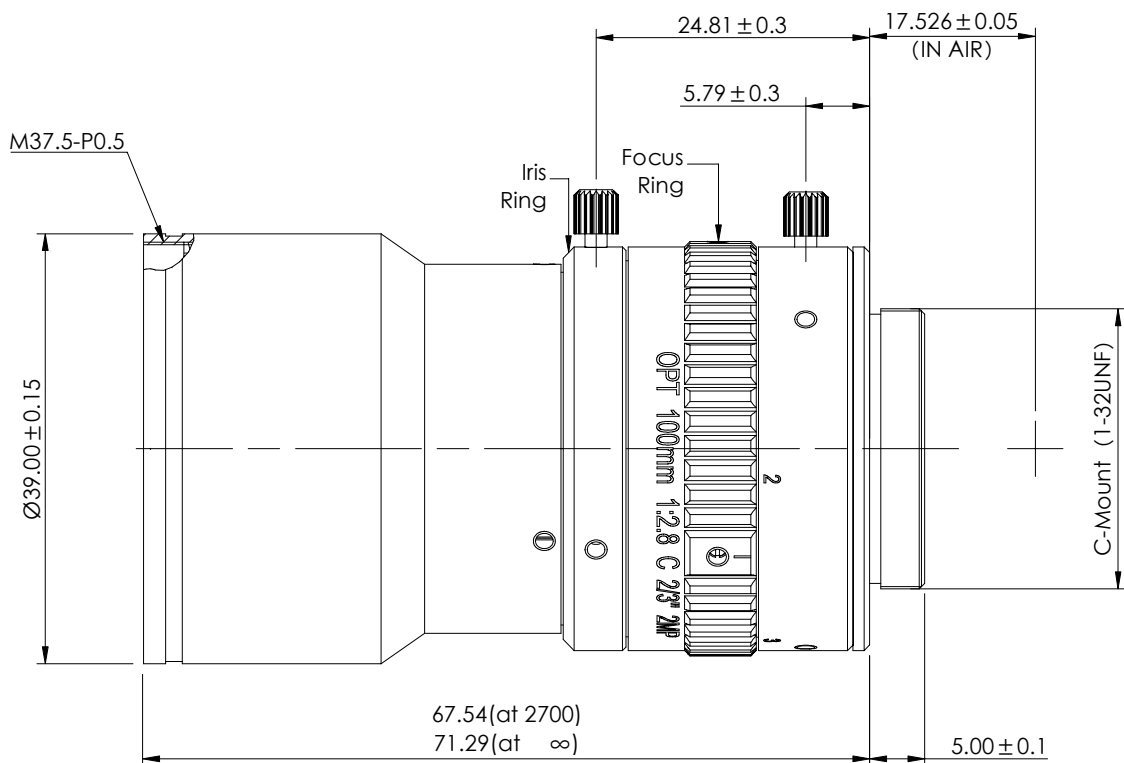

View Angle	
	Standard Difference
Copyright © 2020 by OPT All Rights Reserved	IT14
Drawing Code	

Item	Signature	Date
Drawing		
Design		
Check		
Approve		
Paper Size	A4	
Revised Date	2020-05-04	

		OPT Machine Vision Co., Ltd.	
OPT-C10028-2M-V1.0			
Scale		Page	1/1 Total Page
Version	A01		